

# Installation Manual

## ELECTRIC STRIKE FES20M

### PRODUCT

FES20M Monitored Strike (SCEC approved)

### ACCESSORIES

#### Extension Lips.

FES20-EL 15 (15mm)

FES20-EL 25 (25mm)

FES20-EL 50 (50mm)

FES20-EL 75 (75mm)

#### Silencer Rubber Buffer

The FES20M is now equipped with the option to install a Silencer Rubber Buffer. To install the Silencer Rubber Buffer (supplied in the installation kit), simply remove the screw located between the body of the strike & the keeper and replace it with the buffer (see instruction on last page).

### WIRING

<b>Power Input</b>	Multi Voltage 11-30VDC	12 VDC – current 220 mA	24 VDC – current 110 mA
<b>Wire output</b>	Red (+)	Black (-)	
<b>LSS (Lock Status Sensor)</b>	Black (Common)	Yellow (NO-PTO); (NC-PTL)	Green (NC- PTO); (NO-PTL)
<b>DSS(Door Status Sensor)</b>	Black (Common)	Blue (NO)	Orange (NC)
<b>ATS (Anti – tamper Sensor)</b>	Black (Common)	Red (NO)	White (NC)
<b>Sensor Output</b>	LSS Sensor Output 3 A, 125 VAC; 2 A, 30 VDC.	DSS Sensor Output 3 A, 125 VAC; 2 A, 30 VDC.	Anti-tamper Sensor Output 5 A, 125 VAC; 3 A, 250 VAC.

### NOTE

FES20 Series Electric Strike factory setting is Power to Lock (PTL).  
The control circuit for the door strike is protected against reverse polarity connection.  
No additional diode protection required.

## PRODUCT DIMENSIONS

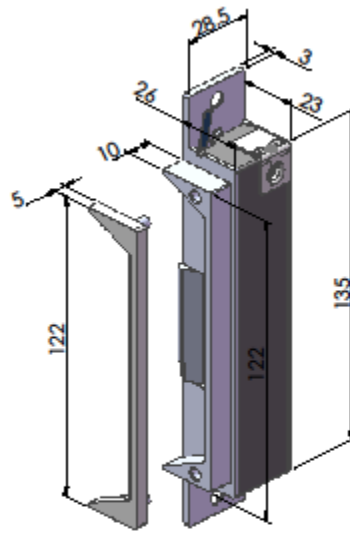
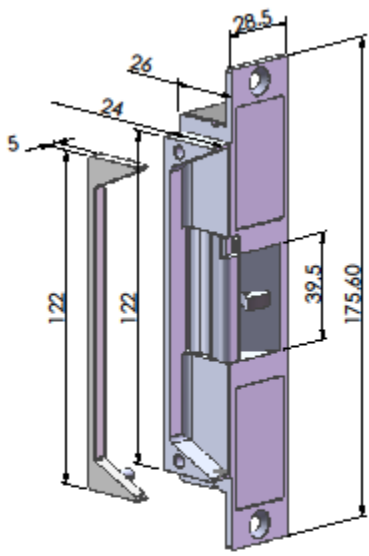

# INSTALLATION

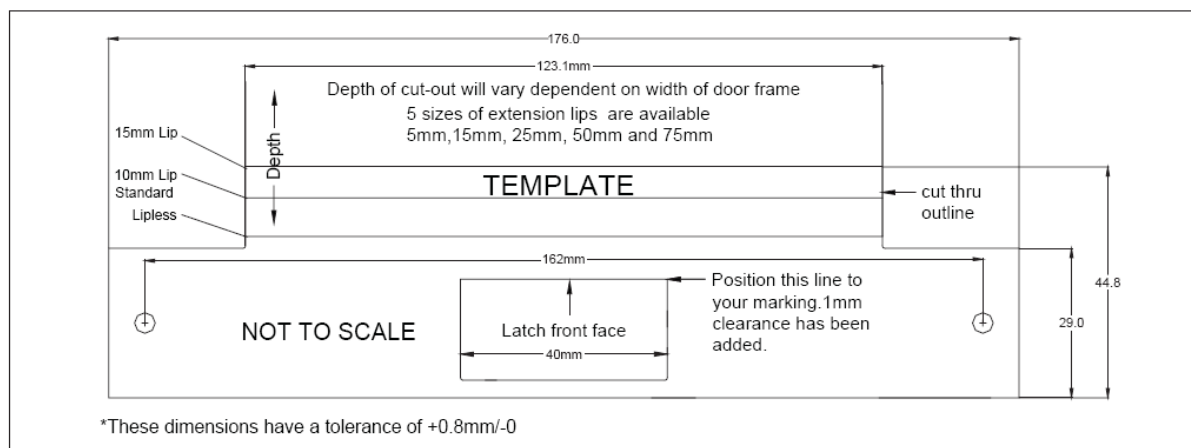
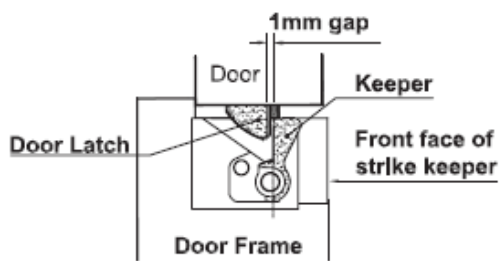
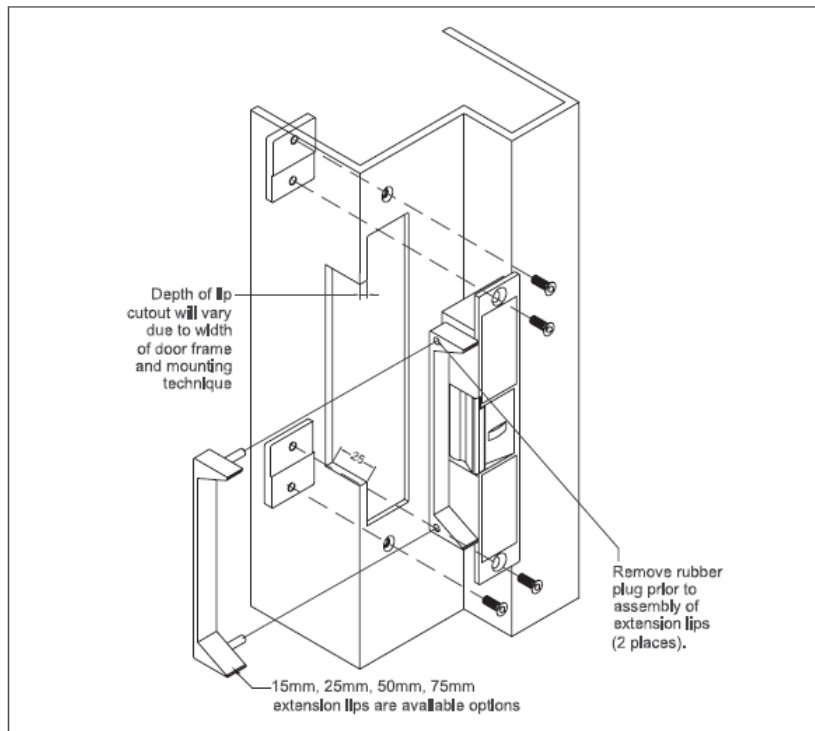

If the frame is not prefabricated, use the enclosed stick-on template to prepare strike cut-out in frame. Install strike as described in diagram.

## POSITION OF DOOR LATCH

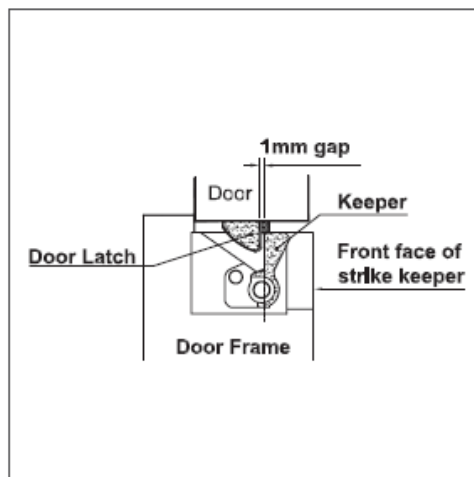
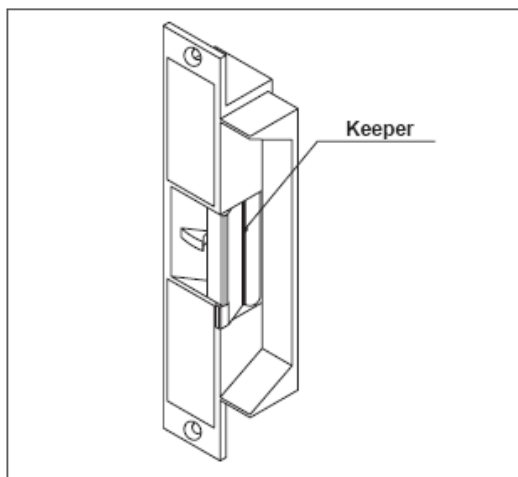

As drawn in the diagrams, there should be a 1mm gap between the door latch and the front-face of the strike keeper, preventing the door from creating back pressure on the strike keeper when the door is closed.

## CONVERSION FROM EX-FACTORY SETTING PTL (POWER TO LOCK) TO PTO (POWER TO OPEN)

- 1

Prepare changeover tool

- 2

Fully loosen both of the capstan release screws (screws are captured by the plastic grommet)

- 3

Remove the rubber cap to expose the capstan changeover wheel

- 4

Insert the changeover tool through the window. Turn the capstan wheel in the direction away from the strike keeper (see arrow on sticker PTO). Turn the wheel until it hits the stop. The strike is now in Power to Open/Fail Secure mode



- 5

Tighten the two capstan releasing screws replace and plug in the rubber cap back to close the window.

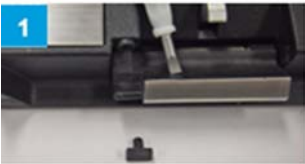

## PROCEDURE TO INSTALL THE SILENCER RUBBER BUFFER

- 1



Remove the silencer rubber buffer from accessory kit
- 2



Remove the buffer screw
- 3



Replace screw with rubber buffer