

CP155B

Weather Resistant Keypad With Prox



Security Systems

EN

Installer Reference Guide
Security System

BOSCH

CP155B - WEATHER RESISTANT KEYPAD WITH PROX

The CP155B keypad provides alarm and or access control functionality when used on selected Solution security control panels. It is fitted with built in smart prox reader, front and read tamper. Constructed from high strength UV resistant plastic, the CP155B keypad provides a high level of durability and is also weather resistant to IP65 making it ideal for external installations.

The CP155B includes red, green and blue indicators which are used to show area or door lock status. Buttons with backlit make it easy to operate in all lighting conditions.

The keypad connects to the control panel via the RS485 encrypted LAN and occupies a standard keypad position in the panel configuration.

DIP Switch 5

LAN Termination if required can be enabled by placing dip switch 5 in the ON position.

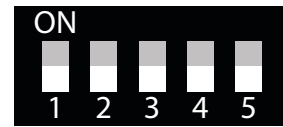

Figure 1: Keypad Address Switch



Only 1 Keypad can be assigned to each address. All keypads are supplied from the factory set to address 1. You must power cycle the panel or perform a LAN scan whenever you change the keypad address.

Box Contents

The CP155B box contains the following parts.

- Keypad and Mounting Plate
- Plug On Connection Cable and Grommet
- Instruction Sheet
- Address Switch Plug
- 1x Proximity Card
- 2 x (M3 x 6mm) Hex Screws
- 1 x 2mm Hex Key

Installation

The keypad should be installed onto a solid surface using suitable mounting fixtures. Wiring should only be performed while the control panel is powered down.

- Step 1) Mark out the location of the mounting holes and the cable exit hole before drilling out all points as necessary. Secure the mounting plate with appropriate fasteners.
- Step 2) If the rear tamper is required, fit the tamper screw securely through the backplate to the wall.
- Step 3) Use the connection diagram [Figure 6] to terminate the supplied cable as required. Unused wires should be insulated to prevent short circuits.
- Step 4) Remove the address grommet to expose the DIP switch and set the required address using [table 2] Be sure to refit the address grommet securely before assembling and mounting the keypad.

Note Each keypad on the system must have a unique address.

CP155B Keypad Compatibility		
Panels Supported	Version	Keypads Supported
Solution 6000	2.25	Up to 16

Table 1: CP155B Compatibility

Various keypad options can be configured via the Devices - Keypad & Readers menu in panel programming. User access events are stored in the panel log and can also be reported if required.

Keypad Addressing

Each keypad fitted to the system must be assigned a unique address on the LAN. The CP155B includes a DIP switch for quick address selection. The following table shows the address setting for each keypad as well as the number of keypad devices each panels can support.

	Keypad Address Setting				
	Address	Switch 1	Switch 2	Switch 3	
Solution 6000 Panel	1				
	2	1			
	3		2		
	4	1	2		
	5			3	
	6	1		3	
	7		2	3	
	8	1	2	3	
	9				4
	10	1			4
	11		2		4
	12	1	2		4
	13			3	4
	14	1		3	4
	15		2	3	4
	16	1	2	3	4

Table 2: Keypad Address

- Step 5) Attach the connection cable to the keypad by plugging in the connector. Note the connector is polarised and will only plug in when correctly aligned. **Do not use excessive force.**
- Step 6) Fit the cable grommet in place by pressing the first flange into the hole and leaving the second flange on the outside of the keypad. Make sure it sits neatly in all places to insure a correct water resistant seal.
- Step 7) Carefully hook the keypad to the backplate and fit the 2 Hex screws using the allen key supplied. **See figure 4-5.**

Keypad Operation

The CP155B keypad can be configured to provide system area control, door access control or both depending on the installation requirements.

As there is no LCD display on the keypad, feedback is provided via the red, green, blue LED's and the keypad sounder.

The CP155B also includes an egress input and lock output which can be used to control door access if required.

Note Using the on board lock output is not recommended when the CP155B is being used on an external wall of the building. In this case it is recommended that you run the lock control wires directly to an output located on the main panel or output expander module located inside the building.

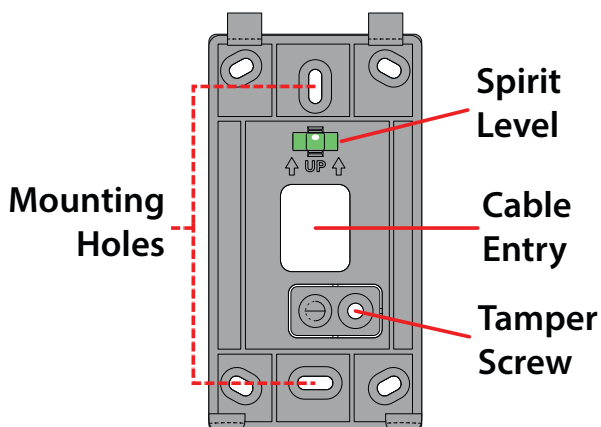

Figure 2: Mounting Bracket

Keypad Button Functions

The CP155B keypad consists of 13 individual buttons which are used to enter PIN and control the system. Some buttons have a secondary functions that are activated by holding the button down for two seconds.

The [#] and [*] buttons perform the same functions as the ON and OFF buttons on the standard display keypad.

Button = ON Button
* Button = OFF Button

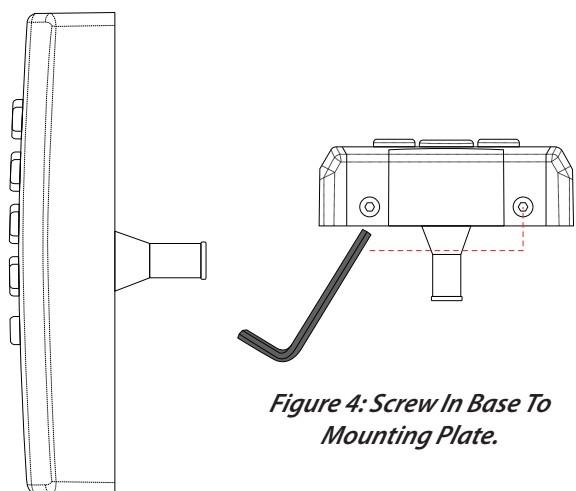

Figure 4: Screw In Base To Mounting Plate.

Figure 3: Assembly Side On

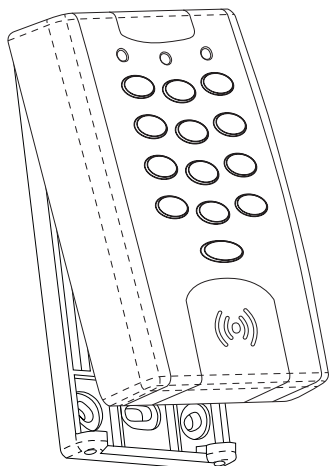

Figure 5: Keypad Mounting angle

Keypad Button Functions	
Button	Description
[0] to [9]	The numeric buttons allow you to enter PIN numbers and other functions when required.
[#]	To arm the system enter the user PIN followed by the [#] key. The [#] key performs the same function as the ON button on display enabled keypads.
[*]	To disarm the system enter the user PIN followed by the [*] key. The [*] key performs the same function as the OFF keypads.
[◇]	TBA

Table 3: Button Functions

Hold Down Functions

The CP155B keypad supports the following hold down functions. These functions will only work if the keypad has been assigned to an area. When keypads are installed outside the premises and are being used for area control, it is recommended that you disable the emergency key functions to prevent nuisance alarms.

See the Devices-Keypads & Readers-Emergency Keys menu option in panel programming to disable these features.

Hold Down Functions	
Function	Meaning
Panic Alarm	Press and hold both the [1] and [3] keys down for 2 seconds to initiate a panic alarm.
Fire Alarm	Press and hold both the [4] and [6] keys down for 2 seconds to initiate a fire alarm.
Medical Alarm	Press and hold both the [7] and [9] keys down for 2 seconds to initiate a medical alarm.
All ON	Enter a valid PIN and then press and hold down the [#] key, the system will turn On or Arm all areas that the user belongs to at the same time.
All OFF	Enter a valid PIN and then press and hold down the [*] key, the system will turn Off or Disarm all areas that the user belongs to at the same time.

Table 4: Hold Down Functions



The hold down 4 - Chime Mode and hold down 6 - Answer Incoming Call features are not currently supported from the CP155B keypad.

Keypad LED Indicators

The CP155B keypad includes RED and GREEN indicator LEDs which provide visual feedback during system operation.

The Red & Green indicators will show alarm &/or area status. The Blue indicator will show door status.



The keypad can display alarm and door status at the same time.

LED Operation For Area Control		
Led	Condition	Meaning
Red	On	Area All On
	Flashing	Area Alarm
Green	On	Area is OFF
	Flashing	Area not ready to turn on - zone(s) unsealed
Red & Green	Both On	Area armed in Part mode and all zones sealed.
Red & Green	Red On and Green Flashing	Area armed in Part mode with zones unsealed.
Red & Green	Alternate Flashing	Keypad initialising during power up or LAN scan.
Red & Green	Both Off	Home Area and Door Assignment not programmed or keypad not powered.

Table 5: Keypad LED's - Area Control

To have the keypad control an area on the alarm system you need to assign the keypad to a home area. See the Devices-Keypads-Home Area menu option in panel programming. If alarm system control is not required then you should set the home area option to No Area.

To have the keypad control a door on the system you will need to assign a door to the keypad. See the Devices-Keypads-Door Assignment menu option in panel programming.

LED Function For Door Control		
Led	Condition	Meaning
Blue	On	Door Locked
Blue	Fast Flash	Door Unlocked
Blue	Continuous Fast Flash	Door manually unlocked or overridden.
Blue	2 Flashes	Door automatically unlocked by time zone
Red & Green	Alternate Flashing	Keypad initialising during power up or LAN scan.
Blue	Off	Door not programmed or keypad not powered.

Table 6: Keypad LED's - Door Control

Once assigned to a door, the on-board Lock output and Egress input will automatically be assigned to the same door as the keypad.

If both alarm area and door control is required then you will need to assign a home area and a door to the keypad.



The CP155B LED indicators will only display the status of the programmed home area. You cannot move between areas from this keypad. If you require multiple area status visibility you should use a display keypad like the CP700B.

Keypad Alert Tones

The CP155B keypad emits several distinct tones to alert you to particular system events. The keypad volume level cannot be adjusted on the CP155B however it can be turned off via panel programming by setting the keypad volume to the lowest level. See Devices-Commands-Volume menu in panel programming.



Setting the keypad volume to off will also stop the key press beep during normal operation.

Keypad Alert Tones	
Event	Alert Tone Emitted
Fire Alarm	If the system registers a fire alarm, the reader will sound 3 short beeps followed by a 1.5 second pause. This will repeat until reset by the user or until the siren run time expires.
Burglary Alarm	If the system registers a burglary alarm, the keypad will sound a continuous siren tone until reset by a user or until the siren run time expires.
Trouble	If a system trouble condition occurs, the keypad will sound 4 x fast short beeps followed by a 5 second pause and will repeat this tone until the user acknowledges the trouble condition from a display keypad
Key Press	The keypad will sound one short beep every time a button is pressed.
Exit Delay	The exit delay warning will sound 1 short beep every second when the area the keypad has been assigned to is armed. During the last 10 seconds of exit time the warning tone will speed up indicating that the time has nearly expired.

Entry Delay	The hi/lo entry delay warning tone will sound once every second when an entry delay zone in the area the keypad has been assigned to is triggered. If the system is not disarmed before the entry time expires then an alarm will occur.
Error	If you press an invalid button during any data entry sequence, the keypad will sound a 2 second warning tone indicating that the command was not accepted.
Chime Alert	If chime mode is active then the keypad will sound fast short beeps to alert the user when a zone programmed for chime is opened. Chime mode is only applicable when the area is disarmed.

Table 7: Keypad Tones



When keypads are installed outside the premises, you may prefer that the alert tones are disabled. See the Devices-Keypads & Readers-Indicator Options menu in panel programming to disable these features.

Egress and Lock Control

The CP155B includes a lock output and egress input which can be used to simplify the wiring when the keypad is being used for access control. The lock output consists of a Form 1c Relay capable of handling 2Amps @ 24v DC which can drive a door lock or trigger a third party device like a gate controller. The output is a clean change over relay contact that is electrically isolated and will operate for a fixed 5 seconds whenever the associated door is operated



The on board lock output will operate for a fixed time period of 5 seconds when triggered. If a different time is required then you should use another output on the system to operate the door lock.

Depending on the system load, the panel power supply may not be sufficient to operate the door lock, especially in cases where it is power to lock and a separate power supply should be fitted. When operating DC door strikes the back EMF energy generated when the lock is released should be shunted with a reverse diode and is not always provided by the door strike manufacturer.

The Egress input [Green Wire] on the CP155B keypad allows you to simplify the wiring required to implement an egress button on the inside of the door. The egress input triggers the lock output on the keypad by operating the associated door that has been assigned to the keypad. The egress input should be connected via a momentary

or push button switch to keypad ground [-]. When the egress button is pressed the lock output on the keypad will trigger for a fixed 5 second period. For greater security, if the egress input is not being used it should be disabled via panel programming. See Devices-Keypads & Readers-General Options in panel programming.



Any zone on the system can be configured to trigger a door and can therefore also be used to operate the lock output on the CP155B.

Configuration Examples

Alarm control function only.

- 1) Install the keypad as per instructions.
- 2) Set the home area for the keypad.
- 3) Set keypad options as required remembering to disable keypad emergency alarms and or single button arming if the unit is being installed externally.
- 4) Assign users to the area.

Access control function only.

- 1) Install the keypad as per instructions.
- 2) Assign the keypad to a door.
- 3) Set keypad options as required.
- 4) Set output to door.
- 5) Set output event assignment.
- 6) Assign users to the door.

Both Alarm and Access control functions.

- 1) Install the keypad as per instructions.
- 2) Set the home area for the keypad.
- 3) Assign the keypad to a door.
- 4) Set keypad options as required remembering to disable keypad emergency alarms and or single button arming if the unit is being installed externally.
- 5) Set output to door.
- 6) Set output event assignment.
- 7) Assign users to the area.
- 8) Assign users to the door.

Examples show how to configure the CP155B to control a door. Consult the control panel installation manual for further programming information.

Smart Card Credentials

There are a number of compatible token styles available to suite your customer. The PR370 is a grey token that incorporates both the EM and Smart Card formats with identical 40bit credential allowing the one token to be used across different technologies.

You may have a site that is running the dated EM format but now installing a new site with the high security Smart Card Format and want to use the same tokens across both sites.



*PR301
Smart Card Token*

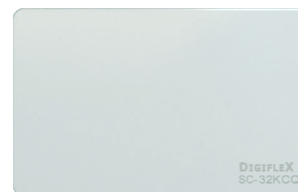

*PR350
Smart Card*



*PR370
Dual Smart Card
Token*



*PR365
Adhesive Sticker*

Connection Diagram

Address Select Switch. Keypads must be set to a unique address as per "Table 2: Keypad Address" on page 2.

All CP155B keypads are supplied from the factory set to Address 1.

You must power circle the panel or perform a LAN scan after connecting the CP155B for the system to initialise the keypad.



Note CP155B Firmware must be 2.01 or later.

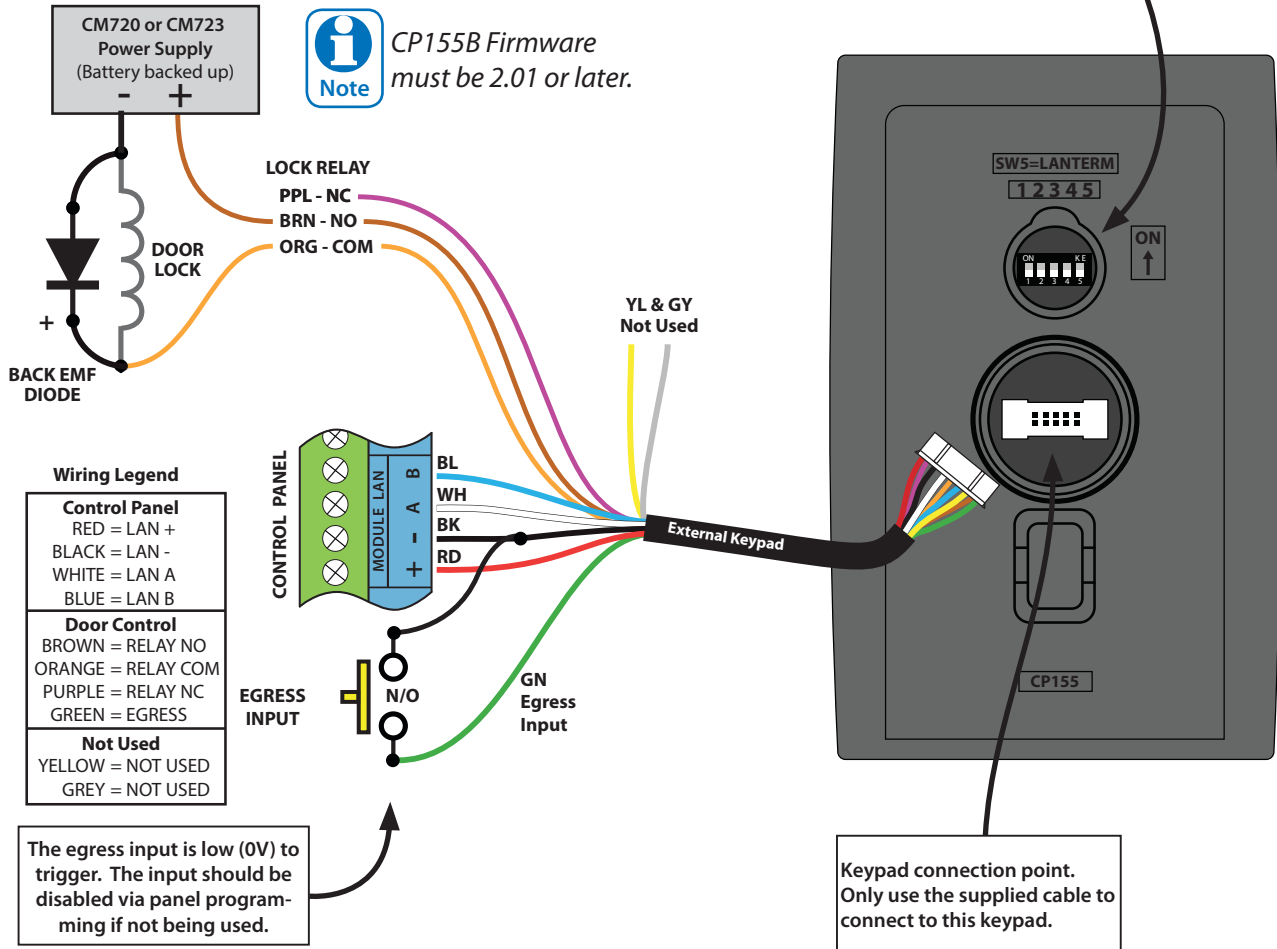

Wiring Legend

Control Panel
RED = LAN +
BLACK = LAN -
WHITE = LAN A
BLUE = LAN B
Door Control
BROWN = RELAY NO
ORANGE = RELAY COM
PURPLE = RELAY NC
GREEN = EGRESS
Not Used
YELLOW = NOT USED
GREY = NOT USED

The egress input is low (0V) to trigger. The input should be disabled via panel programming if not being used.

Keypad connection point. Only use the supplied cable to connect to this keypad.

Figure 6: CP155B Connection Diagram

CP155B Specifications

- Part Number:** CP155B - External Keypad Weather Resistant With Smart Prox.
- Operating Voltage:** 10.0V D.C. - 14.5V D.C. @ 100mA Max.
- Module Connection:** Max total LAN length using multi strand security cable = 500m.
(RS485 LAN) Max total LAN length using 2 pair twisted shielded data cable (Belden 8723) = 1200m.
See the control panel manual for complete wiring instructions.
- Lock Output:** Relay form 1c, 24v DC at 2Amp
- Egress Input:** Low to trigger. Can be disabled via software control.
- Format:** 2 way 13.mhz High Security Encrypted smart Card
Compatible Smart Prox Cards: PR301, PR365, PR370, PR350
- Dimensions:** 83mm(W), 30mm(D), 129mm(H)
- Environment:** -10° to 55°C RH 5 to 93% non-condensing IP65.
- Fixing Method:** The CP155B should be mounted on a sturdy vertical wall using fixtures appropriate for the wall construction type.
- Warranty:** 3 years from date of manufacture (return to base).



In the interest of ongoing product development this document is subject to change without notice.

Bosch Security Systems
Level 2, 21 Solent Circuit
Baulkham Hills, NSW 2153
Australia
Phone: 1300 026 724
www.boschsecurity.com.au

© 2018 Bosch Security Systems
CP155BIRG
Issue FTR1.2

BOSCH